



Watts: 1.888.868.8367 (TOTTENS) Fax: 1.888.232.2205
www.tottengroup.com

FARM INSURANCE APPLICATION

We have a professional duty of confidentiality and are committed to holding personal information in strict confidence. The information provided to us will only be disclosed where required by law to do so or required to do so in conducting negotiations with third parties, such as insurance companies, on your behalf.

We will further safeguard the security of such information in a manner appropriate to sensitivity of that information.

Broker Name: _____

Broker's Email Address: _____

Name and mailing address of applicant: _____

Postal Code: _____

This application is: New Renewal of # _____ Rewrite of #: _____ Other policy #'s _____

Policy period - from: _____ to _____
Day Month Year Day Month Year Policy period shall be 12:01 Standard Time at the address of the Insured

Location of Property Owned or Leased	Loc #	Lot	Concession	Township, County	Acreage
	1				
	2				
	3				
	4				

Loss (if any) Payable to: (Absence of entry denotes "to Insured")	Loc #	Name	Address (including postal code)

Type of Dairy Beef - # of Head (150 max) _____ Horse General
Farm Vegetable/Fruit Cash Crop Hobby Other (specify) _____

QUESTIONNAIRE

Number of years applicant has been at this address _____ Is farming the primary occupation of the applicant? Yes No

Have you personally inspected this property? Yes No Date _____ Do you personally know the applicant? Yes No

Current Carrier? _____ from _____ to _____ Policy # _____

Is Current Carrier offering renewal? Yes No If no, why not _____

- To your knowledge is there any other property within 150' insured by this Company? Yes No
- Are these locations accessible by roads/lanes/driveways kept open year round? Yes No
- Has the applicant had any loss in the last five years, whether insured or not? (Please list) Yes No

4. Has any company ever cancelled or declined to insure the applicant, property or operation? Yes No

Reason: _____

5. Does (or will) THIS COMPANY have other insurance on this risk? (describe in Notes Section below) Yes No

6. Will there be other insurance in force on either building, contents or operations? (describe in Notes Section below) Yes No

7. Any premises owned, occupied or operated by the Applicant & not described on this application? (describe in Notes Section below) Yes No

8. In your opinion are there any buildings that are NOT insurable for windstorm? (describe in Notes Section below) Yes No

Notes



Dwelling # _____

Occupancy _____ **Construction** _____ **Heating** _____ **Auxiliary** _____ **Year Dwelling Constructed** _____

Owner's Principal Dwelling _____ Furnace (central) Fireplace * _____
 Relative _____ Roof _____ Electric Wood Stove * _____
 Farm Manager _____ Combination Pellet/Corn _____
 Tenant _____ Other * _____ # face cord _____
 Vacant *****FUEL USED** _____
 Seasonal _____
 Other _____

If over 20 years old, please complete below

	Full	Part	None	Year Updated
Electrical	<input type="checkbox"/>	<input type="checkbox"/>	<input type="checkbox"/>	_____
Heating	<input type="checkbox"/>	<input type="checkbox"/>	<input type="checkbox"/>	_____
Plumbing	<input type="checkbox"/>	<input type="checkbox"/>	<input type="checkbox"/>	_____
Roofing	<input type="checkbox"/>	<input type="checkbox"/>	<input type="checkbox"/>	_____

Number of Families: _____
 Number of stories: _____
 Square Feet: _____

Structure Type

Detached
 Mobile Home
 Other _____

Protection

Within 300 m of Hydrant
 Within 5 km of a Fire Hall
 Within 13 km of a Fire Hall
 Over 13 km from a Fire Hall

Private Protection

Fire Alarm Yes No Local Central Station
 Burglar Alarm Yes No Local Central Station
 Responding Fire Hall: _____

Farmowners/Dwelling # _____	2 Detached Private Structures	3 Unscheduled Personal Property	4 Additional Living Expenses	Deductible
Loc # _____				
\$ _____	\$ _____	\$ _____	\$ _____	\$ _____

Sewer Backup? Yes No (Sewer Back-Up Questionnaire Required) Limit: \$5,000 \$10,000 \$15,000 (max)

Dwelling # _____

Occupancy _____ **Construction** _____ **Heating** _____ **Auxiliary** _____ **Year Dwelling Constructed** _____

Owner's Principal Dwelling _____ Furnace (central) Fireplace * _____
 Relative _____ Roof _____ Electric Wood Stove * _____
 Farm Manager _____ Combination Pellet/Corn _____
 Tenant _____ Other * _____ # face cord _____
 Vacant *****FUEL USED** _____
 Seasonal _____
 Other _____

If over 20 years old, please complete below

	Full	Part	None	Year Updated
Electrical	<input type="checkbox"/>	<input type="checkbox"/>	<input type="checkbox"/>	_____
Heating	<input type="checkbox"/>	<input type="checkbox"/>	<input type="checkbox"/>	_____
Plumbing	<input type="checkbox"/>	<input type="checkbox"/>	<input type="checkbox"/>	_____
Roofing	<input type="checkbox"/>	<input type="checkbox"/>	<input type="checkbox"/>	_____

Number of Families: _____
 Number of stories: _____
 Square Feet: _____

Structure Type

Detached
 Mobile Home
 Other _____

Protection

Within 300 m of Hydrant
 Within 5 km of a Fire Hall
 Within 13 km of a Fire Hall
 Over 13 km from a Fire Hall

Private Protection

Fire Alarm Yes No Local Central Station
 Burglar Alarm Yes No Local Central Station
 Responding Fire Hall: _____

Farmowners/Dwelling # _____	2 Detached Private Structures	3 Unscheduled Personal Property	4 Additional Living Expenses	Deductible
Loc # _____				
\$ _____	\$ _____	\$ _____	\$ _____	\$ _____

Sewer Backup? Yes No (Sewer Back-Up Questionnaire Required) Limit: \$5,000 \$10,000 \$15,000 (max)

Please attach for each location, where applicable: **Attach Replacement Cost Calculator - (Include debris removal)**
Attach Wood Burning Questionnaire (if applicable)
Attach Fuel Oil Tank Questionnaire (if applicable)
Attach Sewer Backup Questionnaire



Dwelling # _____

Occupancy _____ **Construction** _____ **Heating** _____ **Auxiliary** _____ **Year Dwelling Constructed** _____

Owner's Principal Dwelling _____ Furnace (central) Fireplace *

Relative _____ **Roof** _____ Electric Wood Stove *

Farm Manager _____ Combination Pellet/Corn _____

Tenant _____ Other * _____ # face cord _____

Vacant _____ *****FUEL USED** _____

Seasonal _____

Other _____

If over 20 years old, please complete below

	Full	Part	None	Year Updated
Electrical	<input type="checkbox"/>	<input type="checkbox"/>	<input type="checkbox"/>	_____
Heating	<input type="checkbox"/>	<input type="checkbox"/>	<input type="checkbox"/>	_____
Plumbing	<input type="checkbox"/>	<input type="checkbox"/>	<input type="checkbox"/>	_____
Roofing	<input type="checkbox"/>	<input type="checkbox"/>	<input type="checkbox"/>	_____

Number of Families: _____

Number of stories: _____

Square Feet: _____

Structure Type

Detached

Mobile Home

Other _____

Protection

Within 300 m of Hydrant

Within 5 km of a Fire Hall

Within 13 km of a Fire Hall

Over 13 km from a Fire Hall

Private Protection

Fire Alarm Yes No Local Central Station

Burglar Alarm Yes No Local Central Station

Responding Fire Hall: _____

Farmowners/Dwelling # _____	2 Detached Private Structures	3 Unscheduled Personal Property	4 Additional Living Expenses	Deductible
Loc # _____				
\$ _____	\$ _____	\$ _____	\$ _____	\$ _____

Sewer Backup? Yes No *(Sewer Back-Up Questionnaire Required)* Limit: \$5,000 \$10,000 \$15,000 (max)

Personal Articles Floater (Attach current jewellery appraisal)

Description	Deductible	Limit
Total		

Outboard Motor and/or Boats (including Inboard/Outboard)

ITEM	Manufacturer, Model, Serial Number	Year	Rental	Length, H.P.	Deductible \$:	
						Limit
OUTBOARD BOAT						
OUTBOARD MOTOR						
BOAT TRAILER						
ACCESSORIES/PORTABLE EQUIPMENT						
Total						

Where will boat/motor be stored ashore? _____

If any of the above are rented to others or used for business purposes, show receipts \$ _____

Other Floaters	Description	Deductible	Limit
Total			



FARM LIVESTOCK SCHEDULE

Description	# of Head		Amount per Animal	Building where housed	Deductible		Total Limit
	Grade	Registered			Alarms	Generator	
					(Provide Details)		

FARMERS COMPREHENSIVE LIABILITY The following personal information is required for coverage to apply

MAIN LOCATION		FARMED BY		General Description of Farm		Liability Limit Required
Up to	1,000					
Acres	Total	Insured	Tenant			
Loc#1						
Acres over						
1,000						

OPTIONAL FARM LIABILITY

Additional Insured (NAME) _____

Additional Dwellings and Dwelling Apartments _____ Number of Units _____

Additional Farm Locations _____ Number of farms _____

Saddle or Draft animals: Number of saddle: _____ Number of Draft _____

Use of horses: _____

Charge for swimming pools or ponds (Describe) _____

Ownership of Watercraft: Type _____ Length _____ H.P. _____

Custom Farming: (Describe) _____ Receipts _____

Retail Sales of Farm Products: (Describe) _____ Receipts _____

Other non-farm Business: (Describe) _____ Receipts _____

Other (Describe) _____

Is the public allowed on premises for any reason? Yes No If yes, please explain _____

Is there any processing done on premises? Yes No If yes, please explain: _____

ANNUAL FARM INCOME \$ _____ **Derived from:** _____

TENANTS FIRE LEGAL LIABILITY

Named Perils All Risk Town Grade 1 2 3 4 5

Building	Occupancy	Construction	How Heated	Lot#	Conc.#	Township/Town	Limit



FARMERS LIMITED POLLUTION LIABILITY - NO COVERAGE UNTIL CONFIRMED BY INSURER

Part - 1

- A) Do you apply pesticides, herbicides or chemical fertilizers AWAY FROM premises you own, rent or lease? Yes No
- B) Do you process or sell any chemicals (fertilizers, insecticides, herbicides) or store any of these chemicals for other than your own use? Yes No
- C) Do you perform any processing operations involving chemicals? Yes No
- D) Do gross receipts from Custom Farming exceed your other farming income? Yes No
- E) Do you have occasion to have polychlorinated biphenyls (PCB's) used or stored? Yes No
- F) Are there any government statutes, standards or regulations (federal, provincial or municipal) for the protection of the environment with which to your knowledge, you do not comply? Yes No
- G) Claims or Loss experience: Have there been any pollution or environmental occurrences in the past, whether insured or not? Yes No
- H) Has pollution liability coverage been declined to you in the past? (if yes, provide details) Yes No

Part - 2

- I) Do you have pollution coverage currently in effect? Yes No
If yes, provide Company _____ Policy # _____ Expiry date _____
- J) Are there any creeks, rivers or other bodies of water on premises you own, rent, lease or do work on? (if yes, describe) Yes No

- K) Do you have any underground or above ground tanks or tanks stored indoors? (if yes, complete TANK DATA SUPPLEMENT below) Yes No

TANK DATA SUPPLEMENT

Although information is required on all tanks, no underground piping of tanks are covered by this policy.

1) Is there written tank filling procedure containing information to prevent spills or overflows? Yes No

2) Is there a written emergency procedure outlining actions to be taken in the event of a tank spill or overflow? Yes No

Loc. #	Tank #	Construction (see below)	Age (yrs)	Product Stored (see below)	Capacity (in 1000 litres)	Above or Below Ground	If above, is it Dyked?	Indoors or outdoors	High level alarm?

CONSTRUCTION W-Welded R-Riveted B-Bolted F-Fibre Glass L-Lined (Example: a lead lined welded steel tank used for acid storage would show as "WL") PRODUCT STORED: give generic names, not product or trade names	Limited Pollution		Deductible \$ _____
	LIMITS	MAIN FARM (up to 200 acres)	_____
	each occurrence	Additional locations #	_____
	\$ _____	Pond/Marsh with outflow #	_____
	Aggregate Limit	Above ground tanks #	_____
\$ _____		Other _____	



TAX Are you registered for retail tax exemption? Yes No If yes, provide # _____

INFORMATION Are you registered for the Goods and Services Tax? Yes No If yes, provide # _____

Sole Proprietor Partnership Corporation Other (specify) _____

Please provide names of all partners or corporate officers who have fiduciary interest in land(L), machinery (M), chattles (C), or horses (H) on a separate page.

N

S

W E

DIAGRAM: Indicate all structures (whether insured or not) - Show distance between all buildings - A separate diagram is required for each location

IT IS HEREBY UNDERSTOOD THAT AN INSPECTION OF THE RISK MAY BE DONE AT ANY TIME

Consumer and previous insurance reports containing personal, credit, factual or investigative information about the applicant may be sought in connection with this application of insurance or a renewal, extension or variation thereof.

I HAVE READ AND ANSWERED ALL THE QUESTIONS IN THIS APPLICATION PERTAINING TO PROPERTY AND LIABILITY COVERAGE AND FIND THEM TO BE CORRECT.

Dated at _____ this _____ day of _____ in the year of _____

Name of Insurance Brokerage/Account Executive

Signature of Agent/Broker

Signature of Applicant



WOOD BURNING QUESTIONNAIRE

Broker: _____

Insured: _____ Policy Number _____

Wood Burning Furnace or Stove

Type of Unit:

Stove Is unit airtight? Yes No

What is the clearance rating for: Stove? _____ Heat Shields _____ Stove Pipes? _____

Fireplace Insert

Add on Furnace Hot Water Hot Air

Other (describe) _____

Make of Unit: _____ Was unit professionally installed? Yes No

Approval:

Is the Unit: C.S.A. Labeled U.L.C. Labeled W.H. Labeled Not Labeled

Usage:

How many face cords of wood are used annually? _____

Seasoning:

How long is the wood seasoned before burning? _____

Chimney Details:

Brick (unlined) Brick (tile lined) Approved Metal (wood rated)

Other (describe) _____

List other units using this chimney: _____

What order (starting at the bottom) do all units enter the chimney? _____

How often is the chimney cleaned? _____

Furnaces:

Is the furnace equipped with automatic controls to bring on oil furnace when fire gets low? Yes No

If hot air, what changes were made in the ductwork of the house when the unit was installed? _____

Additional remarks or information: _____

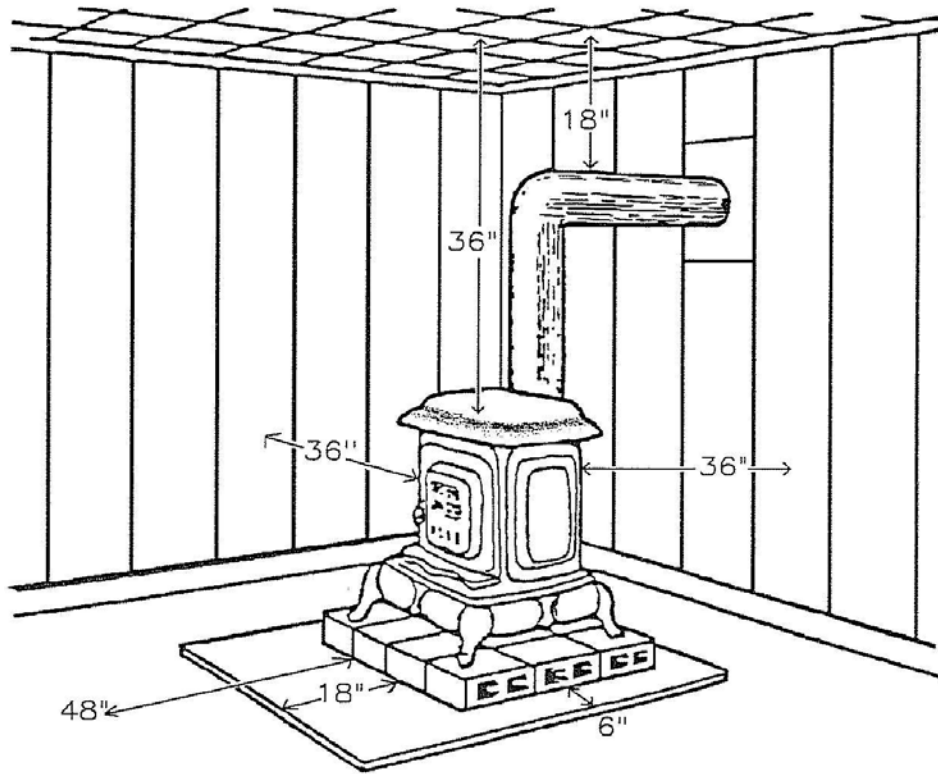

Wood Burning Stoves

- 1. Is stove free of large cracks or broken parts? Yes No
- 2. Is stove located on non-combustible floor materials? Yes No
- 3. Does floor protection extend at least 6" from sides and back and 18" to the front? Yes No
- 4. Is the stove spaced at least 48" from any combustible materials? Yes No
- 5. Is there at least 18" between the top of the stove pipe & ceiling? Yes No
- 6. Does stove pipe fit snugly into thimble? Yes No
- 7. Is stove pipe routed so as not to pass through floors, closets, concealed spaces, or connected to chimney in attic? Yes No
- 8. Does stove have an automatic draft regulator or built in damper? Yes No
- 9. Does stove pipe enter fireplace chimney?
If so, does it enter horizontally at a point higher than outlet or stove fire box? Yes No
- 10. Where is the stove located in the building? _____
- 11. Is there any ductwork over the stove to allow heat to be dispensed to other parts of the house? Yes No

Comments: _____

Inspected by: _____ Date: _____



APPLICANT/INSURED: _____ REF #: _____

LOCATION: _____

Sewer Back-Up Questionnaire

Please provide the following information:

1. Age of building: _____

2. How long has the Insured occupied this building? _____

3. Is "Stock" or "Equipment" stored in basement? Yes No If "yes" provide details: _____

4. a) Is there any previous "history" of sewer back-up or water influx, escape or flood? Yes No

b) If yes, please provide details including what corrective measures have been taken _____

c) Was this damage insured? Yes No

d) If "yes": policy # _____ Name of Insurer: _____

5. Is the building located in an area prone to flooding? Yes No

6. Distance to nearest body of water (i.e. river, creek, etc.) _____

7. a) Is there an automatic sump pump? Yes No

b) Is there a battery back up device for the sump pump? Yes No

8. Is the building on a septic system or sewer system? _____

9. Are the "Septic and Storm Sewer Systems" separate from one another or is it one system? _____

10. When was the septic or sewer system last updated? _____

11. Municipal or private system? _____

12. Other information: _____

Questionnaire completed by: _____ Dated: _____